

3-WHEEL ELECTRIC



3000 - 4000 LBS.

SPECIFICATIONS



8FBE15U-20U | 8FBES15U | 8FBEH18U

CLASS

1

ELECTRIC MOTOR RIDERS

ToyotaForklift.com

3-WHEEL ELECTRIC

CAPACITY
3000 - 4000 LBS.

WHEELBASE
47.6 - 55.1 IN.

LIFT HEIGHT
277.5 IN.

INDUSTRIES



Beverage



Cold Storage



Distribution



Food Storage



General Manufacturing



General Warehousing



Retail

STANDARD FEATURES

SUPPORT

- Active Mast Control (AMC)
 - Forward tilt angle control
 - Rear tilt speed control
 - Lift speed limitation with forward tilt
- Wet disc brakes
- Operator Presence Sensing System (OPSS)
- Momentary hold/controlled descent
- Key lowering interlock
- Foot-operated parking brake
- Electric horn
- Manual return to neutral
- Turn speed control

PERFORMANCE

- 36-Volt electrical system
- AC drive system
- AC lift system
- Programmable hydraulics
- UL-approved model type E
- Transverse-mounted AC drive motors
- Power select functions (E.S.P.H.)
- Digital multifunction display
 - Time & date
 - Speedometer
 - Multifunction hour meter
 - Battery capacity indicator
 - Parking brake indicator
 - Over-discharge warning (lift interrupt)
 - Mast tilt indicator
- Maximum speed limiter
- Power keep function
- 3-way hydraulic control valve
- Programmable auto-off system
- Three forms of energy regeneration
 - Coast control
 - Plug braking
 - Foot braking

BODY/EXTERIOR DESIGN

- Wide-view 2-stage mast (V)
- Punched plate entry/exit step
- Bolt-on overhead guard
- Smooth cushion tires (dual steer tires)
- 36"-wide ITA class II fork carriage
- 48" load backrest extension
- 90°-wide-opening battery hood
- 42" tapered forks
- 81" OHG height
- SB 350 battery connector (gray)
- Drawbar pin

OPERABILITY & ERGONOMICS

- Strategically configured instrument display
- On-demand, hydrostatic power steering
- Cowl-mounted hydraulic controls
- Automatic fork-leveling control
- Large dual operator assist grips
- Operator restraint system (ORS) with full-suspension seat
- Retractable seat belt
- Electric directional shift control
- Memory-tilt steering column
- Hood-integrated paper clip
- Heavy-duty slip-resistant floor mat
- Two-spoke steering wheel
- Integrated switch for headlight & turn signal
- Dash-mounted cup holder
- Curvilinear OHG front pillars

SERVICEABILITY

- Maintenance-free AC motors
- Thermal protection monitor
- Easy-access controllers
- Programmable maintenance timer
- Battery compartment hood assist damper
- Easy access no-tools floorboard
- Built-in analyzer
- Self-diagnostics

OPTIONAL EQUIPMENT

- UL-approved model type "EE"
- UL-approved model type "ES"
- 48-Volt electrical system
- Air-filled pneumatic tires (3-3.5K)
- Solid pneumatic tires
- Non-marking tires
- Mini-lever controls
- Cold storage model
- Battery roll-out or slide-out
- 4-way hydraulic control valve
- Battery compartment side panels
- EZ Pedal (foot directional control)
- Cloth 4-way adjustable full-suspension seat
- String cutter
- Rear assist grip with horn button
- PIN code entry system (with 10-digit keypad)
- Shock sensor
- Special paint (1-2 colors)
- Cloth 12° swivel seat
- Battery connector color (blue, red, or yellow)
- Sideshifter
- Drive-in rack OHG
- Rearview mirrors (left & right)
- 12-Volt power supply
- Inset headlights within OHG
- Operator compartment light
- Strobe lights (yellow or red)
- LED front headlights
- Front/rear combination lights
- LED rear combination lights
- Rear working light
- Key-off headlight system
- Adjustable volume back up alarm (smart alarm)
- Anti-static strap
- Wide-view full free-lift 2-stage mast (FV)
- Wide-view full free-lift 3-stage mast (FSV)
- Open-view full free-lift 3-stage mast (FSW)
- Wide-view full free-lift 4-stage mast (QFV)
- Polycarbonate OHG cover
- Inching while braking
- Keyless ignition
- Fully tapered & polished forks (FTP)
- 40"-wide carriage
- Various load backrest extension heights
- Mast tilt (bottler's tilt 10° forward/5° backward)
- Tilt cylinder boots
- Front protector cover
- Side hosing termination
- Fire extinguisher
- Quick disconnects (single & dual)
- Steering wheel with knob
- Synchronized steering (steering wheel knob is recommended)
- Clamp release interlock systems
- Auto speed control
- Emergency power shutdown button
- Orange seatbelt
- Integral side-shifting fork positioner
- Reverse activated blue spotlight
- Fast charge

TRUCK SPECIFICATIONS

MODEL NUMBERS

GENERAL DATA				8FBE15U	8FBES15U	8FBE18U	8FBEH18U	8FBE20U
Load Capacity (with 24" load center)	lb			3000	3000	3500	3500	4000
Service Brake / Parking Brake				Wet Disc (Foot) / Mechanical (Foot)				
Power Type				Battery				
EXTERIOR DIMENSIONS				8FBE15U	8FBES15U	8FBE18U	8FBEH18U	8FBE20U
A Maximum Fork Height (MFH)	in			119	119	119	119	119.5
B Mast Lowered Height	in			77.6	77.6	77.6	77.6	77.6
C Mast Extended Height (top of load backrest)	in			167.5	167.5	167.5	167.5	167.7
D Free-Lift (top of forks)	in			5.7	5.7	5.7	5.7	5.9
E Load Distance ¹	in			13.8	13.8	13.8	13.8	14.4
F Wheelbase	in			51.6	47.6	51.6	55.1	55.1
G Fork Size (T x W x L)	in			1.4 x 4 x 42	1.4 x 4 x 42	1.4 x 4 x 42	1.4 x 4 x 42	1.6 x 5 x 42
H Length to Fork Face	in			72	69	74.2	76.4	77.2
I Overhead Guard Height	in			81	81	81	81	81
J Tilt Range (forward / backward)	deg			5 / 6.5	5 / 6.5	5 / 6.5	5 / 6.5	5 / 6.5
K Outside Turning Radius	in			58.3	55.1	60.5	62.8	62.8
L Overall Width	in			41.5 [42.1]	41.5 [42.1]	41.5 [42.1]	41.5 [42.1]	41.5
M Carriage Width	in			36	36	36	36	36
N Tread Width	Front	in		34.5 [36]	34.5 [36]	34.5 [36]	34.5 [36]	34.5 [36]
	Rear	in		6.9	6.9	6.9	6.9	6.9
Basic Right-Angle Stacking Aisle Width ²	in (mm)			72.1 (1831)	68.9 (1750)	74.2 (1885)	76.6 (1946)	77.2 (1961)
PERFORMANCE DATA				8FBE15U	8FBES15U	8FBE18U	8FBEH18U	8FBE20U
Maximum Travel Speed (H-mode)	Fwd / Rvs - Full Load	36V	mph	9.9 [9.5]	9.9 [9.5]	9.9 [9.5]	9.9 [9.5]	9.7 [9.8]
	Fwd / Rvs - Full Load	48V	mph	9.9 [9.5]	9.9 [9.5]	9.9 [9.5]	9.9 [9.5]	9.7 [9.8]
	Fwd / Rvs - No Load	36V	mph	9.9 [9.5]	9.9 [9.5]	9.9 [9.5]	9.9 [9.5]	9.9 [9.9]
	Fwd / Rvs - No Load	48V	mph	10.2 [9.8]	10.2 [9.8]	10.2 [9.8]	10.2 [9.8]	9.9 [9.9]
Lift Speed (V mast only)	Full Load	36V / 48V	fpm	77 / 94	77 / 94	71 / 89	71 / 89	67 / 83
	No Load	36V / 48V	fpm	134 / 134	134 / 134	134 / 134	134 / 134	134 / 134
Lowering Speed (V mast only)	Full Load		fpm	104	104	104	104	104
	No Load		fpm	108	108	108	108	108
Maximum Drawbar Pull	Full Load ³		lb	2560	2560	2540	2540	2500
	No Load ³		lb	2540	2540	2540	2540	2520
Maximum Gradeability	Full Load ³		%	27	25	24	24	22
	No Load ³		%	24	22	22	24	22
UNDERCLEARANCE				8FBE15U	8FBES15U	8FBE18U	8FBEH18U	8FBE20U
Center of Wheelbase	in			3.3	3.3	3.3	3.3	3.3
TRUCK WEIGHTS				8FBE15U	8FBES15U	8FBE18U	8FBEH18U	8FBE20U
Gross Weight Without Battery	lb			4620 [4495]	5090 [4970]	4990 [4870]	4700 [4575]	5270 [5190]
Weight Distribution (with standard battery)	Full Load	Front	lb	8450 [8320]	8610 [8485]	9310 [9180]	9500 [9380]	9830 [9765]
		Rear	lb	1030 [960]	1270 [1200]	1090 [1025]	1160 [1090]	1530 [1520]
	No Load	Front	lb	2990 [2865]	2990 [2865]	2940 [2820]	3300 [3175]	3370 [3305]
		Rear	lb	3180 [3110]	3580 [3515]	3590 [3440]	3510 [3440]	4000 [3990]
ATTACHMENT				8FBE15U	8FBES15U	8FBE18U	8FBEH18U	8FBE20U
Attachment Max Operating Hydraulic Pressure	psi			2000	2000	2000	2000	2000
TIRES				8FBE15U	8FBES15U	8FBE18U	8FBEH18U	8FBE20U
Type (front / rear)				Cushion / Cushion [Pneumatic / Pneumatic]				
Size (OD x W x ID)	Drive			18 x 7 x 12-1/8 [18 x 7-8-16PR]	18 x 7 x 12-1/8 [18 x 7-8-16PR]	18 x 7 x 12-1/8 [18 x 7-8-16PR]	18 x 7 x 12-1/8 [18 x 7-8-16PR]	18 x 7 x 12-1/8 [18 x 7-8-16PR]
	Steer			15 x 5 x 11-1/4 [16 x 6-8-10PR]	15 x 5 x 11-1/4 [16 x 6-8-10PR]	15 x 5 x 11-1/4 [16 x 6-8-10PR]	15 x 5 x 11-1/4 [16 x 6-8-10PR]	15 x 5 x 11-1/4 [16 x 6-8-10PR]
POWER SYSTEM				8FBE15U	8FBES15U	8FBE18U	8FBEH18U	8FBE20U
Battery	Voltage / Capacity (6-hour ratings)	STD 36V/48V	Ah	595 / 375	510 / 360	595 / 375	765 / 660	765 / 660
		High 36V/48V	Ah	880 / 660	660 / 440	880 / 660	1100 / 770	1100 / 770
Battery Compartment	Width		in	39.2	39.2	39.2	39.2	39.2
	Length		in	21.7	17.7	21.7	25.1	25.1
	Height		in	24.5	24.5	24.5	24.5	24.5
Battery Weight	Maximum		lb (kg)	-	-	-	-	-
	Minimum		lb (kg)	1543	1475	1543	2105	2105
Electric Motors	Drive	36V/48V	hp (kW)	4.8 x 2 / 5.0 x 2	4.8 x 2 / 5.0 x 2	4.8 x 2 / 5.0 x 2	4.8 x 2 / 5.0 x 2	4.8 x 2 / 5.0 x 2
	Load Handling	36V/48V	hp (kW)	12 / 12	12 / 12	12 / 12	12 / 12	12 / 12
Control Type	Drive			MOSFET Transistor				
	Load Handling			MOSFET Transistor				

EXTERIOR DIMENSIONS

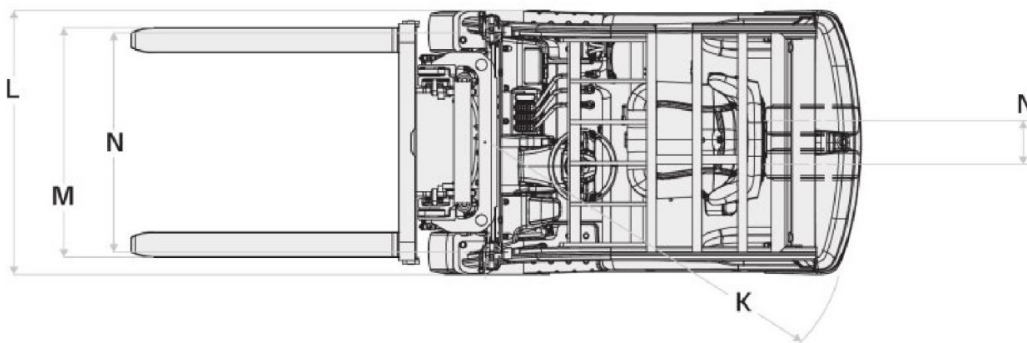
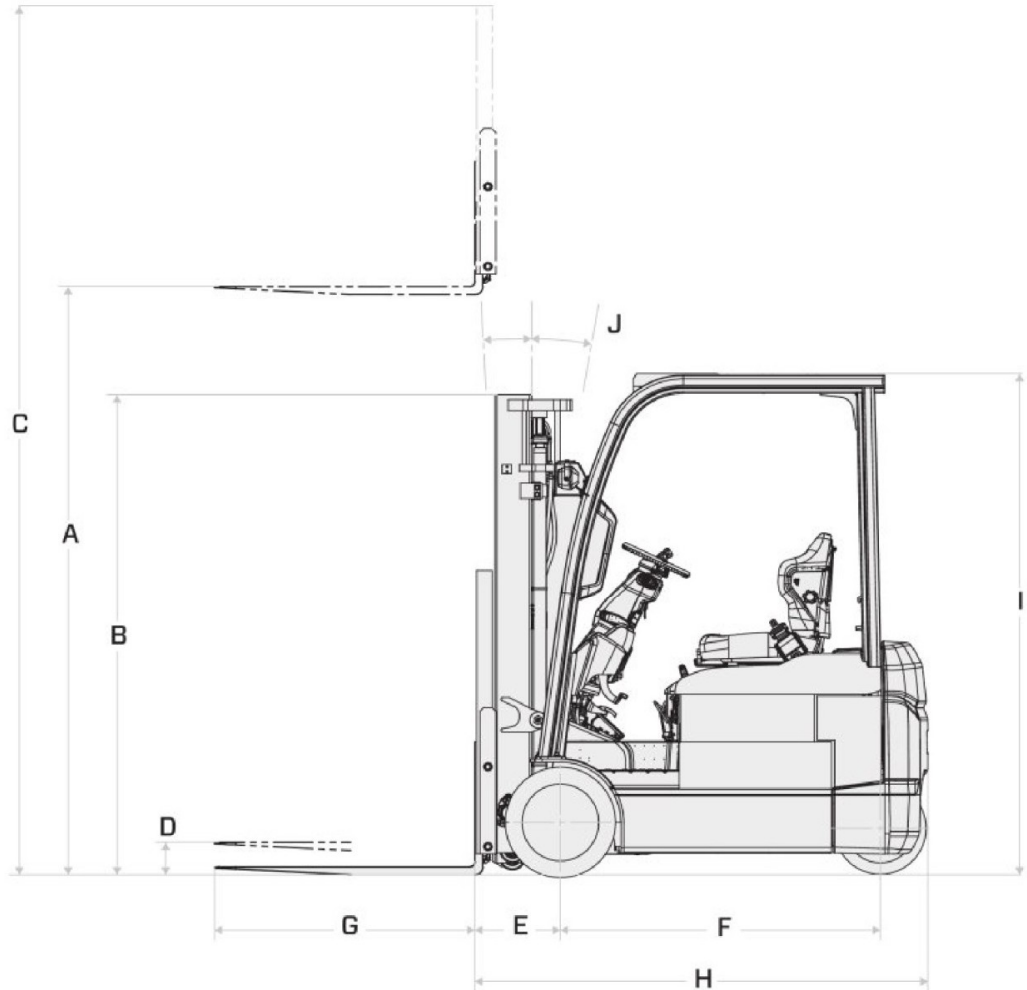

MAST SPECIFICATIONS

MAST TYPE	MAXIMUM FORK HEIGHT (TOP OF FORKS)	OVERALL HEIGHT			FREE-LIFT		TILT RANGE		LOAD CAPACITY AT 24 IN. (610 MM) LOAD CENTER ¹		
		LOWERED	EXTENDED		WITHOUT LOAD BACKREST	WITH STANDARD LOAD BACKREST	FWD	BWD	CUSHION	SOLID PN	AIR-FILLED PN
			WITHOUT LOAD BACKREST	WITH STANDARD LOAD BACKREST							
in (mm)	in (mm)	in (mm)	in (mm)	in (mm)	in (mm)	deg	deg	lb (kg)	lb (kg)	lb (kg)	
8FBES15U											
Wide Visible (V)	100 (2535)	67.7 (1720)	122.2 (3105)	147.8 (3755)	5.7 (145)	5.7 (145)	5	5	3000 (1360)	3000 (1360)	3000 (1360)
	107.5 (2735)	71.7 (1820)	130.1 (3305)	155.7 (3955)	5.7 (145)	5.7 (145)	5	6.5	3000 (1360)	3000 (1360)	3000 (1360)
	119 (3035)	77.6 (1970)	141.9 (3605)	167.5 (4255)	5.7 (145)	5.7 (145)	5	6.5	3000 (1360)	3000 (1360)	3000 (1360)
	131 (3335)	83.5 (2120)	153.7 (3905)	179.3 (4555)	5.7 (145)	5.7 (145)	5	6.5	3000 (1360)	3000 (1360)	3000 (1360)
	139 (3535)	87.4 (2220)	161.6 (4105)	187.2 (4755)	5.7 (145)	5.7 (145)	5	6.5	3000 (1360)	3000 (1360)	3000 (1360)
	147 (3735)	93.7 (2380)	169.5 (4305)	195.1 (4955)	5.7 (145)	5.7 (145)	5	6.5	3000 (1360)	3000 (1360)	3000 (1360)
Full Free-Lift 2-Stage (FV)	158.5 (4035)	101.2 (2570)	181.3 (4605)	206.9 (5255)	5.7 (145)	5.7 (145)	5	6.5	3000 (1360)	2900 (1315)	2870 (1301)
	107.5 (2735)	71.7 (1820)	129.1 (3280)	155.7 (3955)	50.2 (1275)	23.6 (600)	5	6.5	3000 (1360)	3000 (1360)	3000 (1360)
	119 (3035)	77.6 (1970)	140.9 (3580)	167.5 (4255)	56.1 (1425)	29.5 (750)	5	6.5	3000 (1360)	3000 (1360)	3000 (1360)
	131 (3335)	83.5 (2120)	152.8 (3880)	179.3 (4555)	62 (1575)	35.4 (900)	5	6.5	3000 (1360)	3000 (1360)	3000 (1360)
	139 (3535)	87.4 (2220)	160.6 (4080)	187.2 (4755)	65.9 (1675)	39.4 (1000)	5	6.5	3000 (1360)	3000 (1360)	3000 (1360)
	147 (3735)	93.7 (2380)	168.5 (4280)	195.1 (4955)	72.2 (1835)	45.7 (1160)	5	6.5	3000 (1360)	3000 (1360)	3000 (1360)
Full Free-Lift 3-Stage (FSV)	158.5 (4035)	101.2 (2570)	180.3 (4580)	206.9 (5255)	79.7 (2025)	53.1 (1350)	5	6.5	3000 (1360)	2900 (1315)	2870 (1301)
	147 (3735)	69.7 (1770)	168.3 (4275)	195.1 (4955)	48.4 (1230)	21.7 (550)	5	6.5	3000 (1360)	3000 (1360)	3000 (1360)
	158.5 (4035)	73.6 (1870)	180.1 (4575)	206.9 (5255)	52.4 (1330)	25.6 (650)	5	6.5	3000 (1360)	2900 (1315)	2800 (1270)
	170.5 (4335)	77.6 (1970)	191.9 (4875)	218.7 (5555)	56.3 (1430)	29.5 (750)	5	6.5	2900 (1315)	2800 (1270)	2800 (1270)
	189 (4800)	83.5 (2120)	209.6 (5325)	236.4 (6005)	62.2 (1580)	35.4 (900)	5	6.5	2800 (1270)	2700 (1224)	2700 (1224)
	198 (5035)	87.4 (2220)	219.5 (5575)	246.3 (6255)	66.1 (1680)	39.4 (1000)	5	6.5	2800 (1270)	2450 (1111)	2400 (1088)
Open-View Full Free-Lift 3-Stage (FSW)	217.5 (5535)	93.7 (2380)	239.2 (6075)	265.9 (6755)	72.4 (1840)	45.7 (1160)	5	6.5	2400 (1088)	1840 (834)	1790 (811)
	237.5 (6035)	101.2 (2570)	258.9 (6575)	285.6 (7255)	79.9 (2030)	53.1 (1350)	5	6.5	2000 (907)	1440 (653) ¹	1390 (630) ¹
	189 (4800)	83.3 (2115)	207.8 (5275)	236.2 (6000)	63.3 (1605)	35 (890)	5	6.5	2550 (1155)	TSDR	TSDR
	204.5 (5200)	88.3 (2240)	222.8 (5680)	251.2 (6380)	68.3 (1735)	40 (1015)	5	6.5	2425 (1100)	TSDR	TSDR
	224.5 (5700)	95.3 (2420)	243.8 (6195)	272.5 (6920)	75.4 (1915)	47.1 (1195)	5	6.5	2100 (950)	TSDR	TSDR
	228.5 (5800)	99.3 (2520)	246.8 (6265)	275.2 (6990)	79.3 (2015)	51 (1295)	5	6.5	2050 (930)	TSDR	TSDR
Full Free-Lift 4-Stage (QFV)	241.3 (6130)	83.5 (2120)	262.6 (6670)	289.4 (7350)	62.2 (1580)	35.4 (900)	5	3	2200 (998)	1760 (798)	1710 (775)
	259.4 (6590)	89.4 (2270)	281.3 (7145)	307.5 (7810)	68.1 (1730)	41.3 (1050)	5	3	2100 (952)	1650 (748)	1600 (725)
	277.5 (7050)	95.7 (2430)	299.4 (7605)	325.6 (8270)	74.4 (1890)	47.6 (1210)	5	3	1600 (725)	1250 (567) ¹	1200 (544) ¹

MAST TYPE	MAXIMUM FORK HEIGHT (TOP OF FORKS)	OVERALL HEIGHT			FREE-LIFT		TILT RANGE		LOAD CAPACITY AT 24 IN. (610 MM) LOAD CENTER ¹		
		LOWERED	EXTENDED		WITHOUT LOAD BACKREST	WITH STANDARD LOAD BACKREST	FWD	BWD	CUSHION	SOLID PN	AIR-FILLED PN
			WITHOUT LOAD BACKREST	WITH STANDARD LOAD BACKREST							
in (mm)	in (mm)	in (mm)	in (mm)	in (mm)	in (mm)	deg	deg	lb (kg)	lb (kg)	lb (kg)	
8FBES15U											
Wide Visible (V)	100 (2535)	67.7 (1720)	122.2 (3105)	147.8 (3755)	5.7 (145)	5.7 (145)	5	5	3000 (1360)	3000 (1360)	3000 (1360)
	107.5 (2735)	71.7 (1820)	130.1 (3305)	155.7 (3955)	5.7 (145)	5.7 (145)	5	6.5	3000 (1360)	3000 (1360)	3000 (1360)
	119 (3035)	77.6 (1970)	141.9 (3605)	167.5 (4255)	5.7 (145)	5.7 (145)	5	6.5	3000 (1360)	3000 (1360)	3000 (1360)
	131 (3335)	83.5 (2120)	153.7 (3905)	179.3 (4555)	5.7 (145)	5.7 (145)	5	6.5	3000 (1360)	3000 (1360)	3000 (1360)
	139 (3535)	87.4 (2220)	161.6 (4105)	187.2 (4755)	5.7 (145)	5.7 (145)	5	6.5	3000 (1360)	3000 (1360)	3000 (1360)
	147 (3735)	93.7 (2380)	169.5 (4305)	195.1 (4955)	5.7 (145)	5.7 (145)	5	6.5	3000 (1360)	3000 (1360)	3000 (1360)
Full Free-Lift 2-Stage (FV)	158.5 (4035)	101.2 (2570)	181.3 (4605)	206.9 (5255)	5.7 (145)	5.7 (145)	5	6.5	3000 (1360)	3000 (1360)	2950 (1338)
	107.5 (2735)	71.7 (1820)	129.1 (3280)	155.7 (3955)	50.2 (1275)	23.6 (600)	5	6.5	3000 (1360)	3000 (1360)	3000 (1360)
	119 (3035)	77.6 (1970)	140.9 (3580)	167.5 (4255)	56.1 (1425)	29.5 (750)	5	6.5	3000 (1360)	3000 (1360)	3000 (1360)
	131 (3335)	83.5 (2120)	152.8 (3880)	179.3 (4555)	62 (1575)	35.4 (900)	5	6.5	3000 (1360)	3000 (1360)	3000 (1360)
	139 (3535)	87.4 (2220)	160.6 (4080)	187.2 (4755)	65.9 (1675)	39.4 (1000)	5	6.5	3000 (1360)	3000 (1360)	3000 (1360)
	147 (3735)	93.7 (2380)	168.5 (4280)	195.1 (4955)	72.2 (1835)	45.7 (1160)	5	6.5	3000 (1360)	3000 (1360)	3000 (1360)
Full Free-Lift 3-Stage (FSV)	158.5 (4035)	101.2 (2570)	180.3 (4580)	206.9 (5255)	79.7 (2025)	53.1 (1350)	5	6.5	3000 (1360)	3000 (1360)	2950 (1338)
	147 (3735)	69.7 (1770)	168.3 (4275)	195.1 (4955)	48.4 (1230)	21.7 (550)	5	6.5	3000 (1360)	3000 (1360)	3000 (1360)
	158.5 (4035)	73.6 (1870)	180.1 (4575)	206.9 (5255)	52.4 (1330)	25.6 (650)	5	6.5	3000 (1360)	2900 (1315)	2900 (1315)
	170.5 (4335)	77.6 (1970)	191.9 (4875)	218.7 (5555)	56.3 (1430)	29.5 (750)	5	6.5	3000 (1360)	2840 (1288)	2840 (1288)
	189 (4800)	83.5 (2120)	209.6 (5325)	236.4 (6005)	62.2 (1580)	35.4 (900)	5	6.5	2900 (1315)	2740 (1242)	2740 (1242)
	198 (5035)	87.4 (2220)	219.5 (5575)	246.3 (6255)	66.1 (1680)	39.4 (1000)	5	6.5	2800 (1270)	2600 (1179)	2550 (1156)
Open-View Full Free-Lift 3-Stage (FSW)	217.5 (5535)	93.7 (2380)	239.2 (6075)	265.9 (6755)	72.4 (1840)	45.7 (1160)	5	6.5	2600 (1179)	1970 (893)	1920 (870)
	237.5 (6035)	101.2 (2570)	258.9 (6575)	285.6 (7255)	79.9 (2030)	53.1 (1350)	5	6.5	2300 (1043)	1450 (657) ¹	1400 (635) ¹
	189 (4800)	83.3 (2115)	207.8 (5275)	236.2 (6000)	63.3 (1605)	35 (890)	5	6.5	2550 (1155)	TSDR	TSDR
	204.5 (5200)	88.3 (2240)	222.8 (5680)	251.2 (6380)	68.3 (1735)	40 (1015)	5	6.5	2425 (1100)	TSDR	TSDR
	224.5 (5700)	95.3 (2420)	243.8 (6195)	272.5 (6920)	75.4 (1915)	47.1 (1195)	5	6.5	2100 (950)	TSDR	TSDR
	228.5 (5800)	99.3 (2520)	246.8 (6265)	275.2 (6990)	79.3 (2015)	51 (1295)	5	6.5	2050 (930)	TSDR	TSDR
Full Free-Lift 4-Stage (QFV)	241.3 (6130)	83.5 (2120)	262.6 (6670)	289.4 (7350)	62.2 (1580)	35.4 (900)	5	3	2220 (1006)	1820 (825)	1770 (802)
	259.4 (6590)	89.4 (2270)	281.3 (7145)	307.5 (7810)	68.1 (1730)	41.3 (1050)	5	3	2120 (961)	1700 (771)	1650 (748)
	277.5 (7050)	95.7 (2430)	299.4 (7605)	325.6 (8270)	74.4 (1890)	47.6 (1210)	5	3	1620 (734)	1270 (576) ¹	1240 (562) ¹

MAST SPECIFICATIONS

MAST TYPE	MAXIMUM FORK HEIGHT (TOP OF FORKS)	OVERALL HEIGHT			FREE-LIFT		TILT RANGE		LOAD CAPACITY AT 24 IN. (610 MM) LOAD CENTER*			
		LOWERED	EXTENDED		WITHOUT LOAD BACKREST	WITH STANDARD LOAD BACKREST	FWD	BWD	CUSHION	SOLID PN	AIR-FILLED PN	
			WITHOUT LOAD BACKREST	WITH STANDARD LOAD BACKREST								deg
		in (mm)	in (mm)	in (mm)	in (mm)	in (mm)	in (mm)	deg	deg	lb (kg)	lb (kg)	lb (kg)
8FBEBU												
Wide Visible (V)	100 (2535)	67.7 (1720)	122.2 (3105)	147.8 (3755)	5.7 (145)	5.7 (145)	5	5	3500 (1587)	3500 (1587)	3500 (1587)	
	107.5 (2735)	71.7 (1820)	130.1 (3305)	155.7 (3955)	5.7 (145)	5.7 (145)	5	6.5	3500 (1587)	3500 (1587)	3500 (1587)	
	119 (3035)	77.6 (1970)	141.9 (3605)	167.5 (4255)	5.7 (145)	5.7 (145)	5	6.5	3500 (1587)	3500 (1587)	3500 (1587)	
	131 (3335)	83.5 (2120)	153.7 (3905)	179.3 (4555)	5.7 (145)	5.7 (145)	5	6.5	3500 (1587)	3500 (1587)	3500 (1587)	
	139 (3535)	87.4 (2220)	161.6 (4105)	187.2 (4755)	5.7 (145)	5.7 (145)	5	6.5	3500 (1587)	3500 (1587)	3500 (1587)	
	147 (3735)	93.7 (2380)	169.5 (4305)	195.1 (4955)	5.7 (145)	5.7 (145)	5	6.5	3500 (1587)	3500 (1587)	3500 (1587)	
Full Free-Lift 2-Stage (FV)	158.5 (4035)	101.2 (2570)	181.3 (4605)	206.9 (5255)	5.7 (145)	5.7 (145)	5	6.5	3400 (1542)	3400 (1542)	3400 (1542)	
	107.5 (2735)	71.7 (1820)	129.1 (3280)	155.7 (3955)	50.2 (1275)	23.6 (600)	5	6.5	3500 (1587)	3500 (1587)	3500 (1587)	
	119 (3035)	77.6 (1970)	140.9 (3580)	167.5 (4255)	56.1 (1425)	29.5 (750)	5	6.5	3500 (1587)	3500 (1587)	3500 (1587)	
	131 (3335)	83.5 (2120)	152.8 (3880)	179.3 (4555)	62 (1575)	35.4 (900)	5	6.5	3500 (1587)	3500 (1587)	3500 (1587)	
	139 (3535)	87.4 (2220)	160.6 (4080)	187.2 (4755)	65.9 (1675)	39.4 (1000)	5	6.5	3500 (1587)	3500 (1587)	3500 (1587)	
	147 (3735)	93.7 (2380)	168.5 (4280)	195.1 (4955)	72.2 (1835)	45.7 (1160)	5	6.5	3500 (1587)	3500 (1587)	3500 (1587)	
Full Free-Lift 3-Stage (FSV)	158.5 (4035)	101.2 (2570)	180.3 (4580)	206.9 (5255)	79.7 (2025)	53.1 (1350)	5	6.5	3400 (1542)	3400 (1542)	3400 (1542)	
	147 (3735)	69.7 (1770)	168.3 (4275)	195.1 (4955)	48.4 (1230)	21.7 (550)	5	6.5	3400 (1542)	3200 (1451)	3200 (1451)	
	158.5 (4035)	73.6 (1870)	180.1 (4575)	206.9 (5255)	52.4 (1330)	25.6 (650)	5	6.5	3300 (1496)	3200 (1451)	3200 (1451)	
	170.5 (4335)	77.6 (1970)	191.9 (4875)	218.7 (5555)	56.3 (1430)	29.5 (750)	5	6.5	3200 (1451)	3100 (1406)	3100 (1406)	
	189 (4800)	83.5 (2120)	209.6 (5325)	236.4 (6005)	62.2 (1580)	35.4 (900)	5	6.5	3100 (1406)	2800 (1270)	2800 (1270)	
	198 (5035)	87.4 (2220)	219.5 (5575)	246.3 (6255)	66.1 (1680)	39.4 (1000)	5	6.5	2900 (1315)	2630 (1192)	2580 (1170)	
Open-View Full Free-Lift 3-Stage (FSW)	217.5 (5535)	93.7 (2380)	239.2 (6075)	265.9 (6755)	72.4 (1840)	45.7 (1160)	5	6.5	2580 (1170)	1920 (870)	1870 (848)	
	237.5 (6035)	101.2 (2570)	258.9 (6575)	285.6 (7255)	79.9 (2030)	53.1 (1350)	5	6.5	2070 (938)	1530 (694) ¹	480 (671) ¹	
	189 (4800)	83.3 (2115)	207.8 (5275)	236.2 (6000)	63.3 (1605)	35 (890)	5	6.5	2900 (1315)	TSDR	TSDR	
	204.5 (5200)	88.3 (2240)	222.8 (5660)	251.2 (6380)	68.3 (1735)	40 (1015)	5	6.5	2600 (1180)	TSDR	TSDR	
	224.5 (5700)	95.3 (2420)	243.8 (6195)	272.5 (6920)	75.4 (1915)	47.1 (1195)	5	6.5	2275 (1030)	TSDR	TSDR	
	228.5 (5800)	99.3 (2520)	246.8 (6265)	275.2 (6990)	79.3 (2015)	51 (1295)	5	6.5	2200 (995)	TSDR	TSDR	
Full Free-Lift 4-Stage (QFV)	241.3 (6130)	83.5 (2120)	262.6 (6670)	289.4 (7350)	62.2 (1580)	35.4 (900)	5	3	2400 (1089)	1920 (870)	1870 (848)	
	259.4 (6590)	89.4 (2270)	281.3 (7145)	307.5 (7810)	68.1 (1730)	41.3 (1050)	5	3	2300 (1043)	1830 (830)	1680 (807)	
	277.5 (7050)	95.7 (2430)	299.4 (7605)	325.6 (8270)	74.4 (1890)	47.6 (1210)	5	3	1700 (771)	1350 (612) ¹	1300 (589) ¹	

MAST TYPE	MAXIMUM FORK HEIGHT (TOP OF FORKS)	OVERALL HEIGHT			FREE-LIFT		TILT RANGE		LOAD CAPACITY AT 24 IN. (610 MM) LOAD CENTER*			
		LOWERED	EXTENDED		WITHOUT LOAD BACKREST	WITH STANDARD LOAD BACKREST	FWD	BWD	CUSHION	SOLID PN	AIR-FILLED PN	
			WITHOUT LOAD BACKREST	WITH STANDARD LOAD BACKREST								deg
		in (mm)	in (mm)	in (mm)	in (mm)	in (mm)	in (mm)	deg	deg	lb (kg)	lb (kg)	lb (kg)
8FBEBU												
Wide Visible (V)	100 (2535)	67.7 (1720)	122.2 (3105)	147.8 (3755)	5.7 (145)	5.7 (145)	5	5	3500 (1587)	3500 (1587)	3500 (1587)	
	107.5 (2735)	71.7 (1820)	130.1 (3305)	155.7 (3955)	5.7 (145)	5.7 (145)	5	6.5	3500 (1587)	3500 (1587)	3500 (1587)	
	119 (3035)	77.6 (1970)	141.9 (3605)	167.5 (4255)	5.7 (145)	5.7 (145)	5	6.5	3500 (1587)	3500 (1587)	3500 (1587)	
	131 (3335)	83.5 (2120)	153.7 (3905)	179.3 (4555)	5.7 (145)	5.7 (145)	5	6.5	3500 (1587)	3500 (1587)	3500 (1587)	
	139 (3535)	87.4 (2220)	161.6 (4105)	187.2 (4755)	5.7 (145)	5.7 (145)	5	6.5	3500 (1587)	3500 (1587)	3500 (1587)	
	147 (3735)	93.7 (2380)	169.5 (4305)	195.1 (4955)	5.7 (145)	5.7 (145)	5	6.5	3500 (1587)	3500 (1587)	3500 (1587)	
Full Free-Lift 2-Stage (FV)	158.5 (4035)	101.2 (2570)	181.3 (4605)	206.9 (5255)	5.7 (145)	5.7 (145)	5	6.5	3400 (1542)	3400 (1542)	3400 (1542)	
	107.5 (2735)	71.7 (1820)	129.1 (3280)	155.7 (3955)	50.2 (1275)	23.6 (600)	5	6.5	3500 (1587)	3500 (1587)	3500 (1587)	
	119 (3035)	77.6 (1970)	140.9 (3580)	167.5 (4255)	56.1 (1425)	29.5 (750)	5	6.5	3500 (1587)	3500 (1587)	3500 (1587)	
	131 (3335)	83.5 (2120)	152.8 (3880)	179.3 (4555)	62 (1575)	35.4 (900)	5	6.5	3500 (1587)	3500 (1587)	3500 (1587)	
	139 (3535)	87.4 (2220)	160.6 (4080)	187.2 (4755)	65.9 (1675)	39.4 (1000)	5	6.5	3500 (1587)	3500 (1587)	3500 (1587)	
	147 (3735)	93.7 (2380)	168.5 (4280)	195.1 (4955)	72.2 (1835)	45.7 (1160)	5	6.5	3500 (1587)	3500 (1587)	3500 (1587)	
Full Free-Lift 3-Stage (FSV)	158.5 (4035)	101.2 (2570)	180.3 (4580)	206.9 (5255)	79.7 (2025)	53.1 (1350)	5	6.5	3400 (1542)	3400 (1542)	3400 (1542)	
	147 (3735)	69.7 (1770)	168.3 (4275)	195.1 (4955)	48.4 (1230)	21.7 (550)	5	6.5	3400 (1542)	3200 (1451)	3200 (1451)	
	158.5 (4035)	73.6 (1870)	180.1 (4575)	206.9 (5255)	52.4 (1330)	25.6 (650)	5	6.5	3300 (1496)	3200 (1451)	3200 (1451)	
	170.5 (4335)	77.6 (1970)	191.9 (4875)	218.7 (5555)	56.3 (1430)	29.5 (750)	5	6.5	3200 (1451)	3100 (1406)	3100 (1406)	
	189 (4800)	83.5 (2120)	209.6 (5325)	236.4 (6005)	62.2 (1580)	35.4 (900)	5	6.5	3100 (1406)	2800 (1270)	2800 (1270)	
	198 (5035)	87.4 (2220)	219.5 (5575)	246.3 (6255)	66.1 (1680)	39.4 (1000)	5	6.5	2900 (1315)	2630 (1192)	2580 (1170)	
Open-View Full Free-Lift 3-Stage (FSW)	217.5 (5535)	93.7 (2380)	239.2 (6075)	265.9 (6755)	72.4 (1840)	45.7 (1160)	5	6.5	2580 (1170)	1920 (870)	1870 (848)	
	237.5 (6035)	101.2 (2570)	258.9 (6575)	285.6 (7255)	79.9 (2030)	53.1 (1350)	5	6.5	2070 (938)	1530 (694) ¹	480 (671) ¹	
	189 (4800)	83.3 (2115)	207.8 (5275)	236.2 (6000)	63.3 (1605)	35 (890)	5	6.5	2900 (1315)	TSDR	TSDR	
	204.5 (5200)	88.3 (2240)	222.8 (5660)	251.2 (6380)	68.3 (1735)	40 (1015)	5	6.5	2600 (1180)	TSDR	TSDR	
	224.5 (5700)	95.3 (2420)	243.8 (6195)	272.5 (6920)	75.4 (1915)	47.1 (1195)	5	6.5	2275 (1030)	TSDR	TSDR	
	228.5 (5800)	99.3 (2520)	246.8 (6265)	275.2 (6990)	79.3 (2015)	51 (1295)	5	6.5	2200 (995)	TSDR	TSDR	
Full Free-Lift 4-Stage (QFV)	241.3 (6130)	83.5 (2120)	262.6 (6670)	289.4 (7350)	62.2 (1580)	35.4 (900)	5	3	2400 (1089)	1920 (870)	1870 (848)	
	259.4 (6590)	89.4 (2270)	281.3 (7145)	307.5 (7810)	68.1 (1730)	41.3 (1050)	5	3	2300 (1043)	1830 (830)	1680 (807)	
	277.5 (7050)	95.7 (2430)	299.4 (7605)	325.6 (8270)	74.4 (1890)	47.6 (1210)	5	3	1700 (771)	1350 (612) ¹	1300 (589) ¹	

MAST TYPE	MAXIMUM FORK HEIGHT (TOP OF FORKS)	OVERALL HEIGHT				FREE-LIFT		TILT RANGE		LOAD CAPACITY AT 24 IN. (610 MM) LOAD CENTER ¹	
		LOWERED	EXTENDED		WITHOUT LOAD BACKREST	WITH STANDARD LOAD BACKREST	FWD	BWD	CUSHION	SOLID PN	
			WITHOUT LOAD BACKREST	WITH STANDARD LOAD BACKREST							deg
		in (mm)	in (mm)	in (mm)	in (mm)	in (mm)	in (mm)	deg	deg	lb (kg)	lb (kg)
8FBE20U											
Wide Visible (V)	100 (2540)	67.7 (1720)	122.2 (3105)	147.8 (3755)	5.9 (150)	5.9 (150)	5	5	4000 (1814)	3950 (1790)	
	108 (2740)	71.7 (1820)	130.1 (3305)	155.7 (3955)	5.9 (150)	5.9 (150)	5	6.5	4000 (1814)	3950 (1790)	
	119.5 (3040)	77.6 (1970)	141.9 (3605)	167.5 (4255)	5.9 (150)	5.9 (150)	5	6.5	4000 (1814)	3950 (1790)	
	131.5 (3340)	83.5 (2120)	153.7 (3905)	179.3 (4555)	5.9 (150)	5.9 (150)	5	6.5	4000 (1814)	3950 (1790)	
	139 (3540)	87.4 (2220)	161.6 (4105)	187.2 (4755)	5.9 (150)	5.9 (150)	5	6.5	4000 (1814)	3950 (1790)	
	147 (3740)	93.7 (2380)	169.5 (4305)	195.1 (4955)	5.9 (150)	5.9 (150)	5	6.5	4000 (1814)	3950 (1790)	
Full Free-Lift 2-Stage (FV)	159 (4040)	101.2 (2570)	181.3 (4605)	206.9 (5255)	5.9 (150)	5.9 (150)	5	6.5	4000 (1814)	3950 (1790)	
	108 (2740)	71.7 (1820)	129.1 (3280)	155.7 (3955)	50.4 (1280)	23.8 (605)	5	6.5	4000 (1814)	3950 (1790)	
	119.5 (3040)	77.6 (1970)	140.9 (3580)	167.5 (4255)	56.3 (1430)	29.7 (755)	5	6.5	4000 (1814)	3950 (1790)	
	131.5 (3340)	83.5 (2120)	152.8 (3880)	179.3 (4555)	62.2 (1580)	35.6 (905)	5	6.5	4000 (1814)	3950 (1790)	
	139 (3540)	87.4 (2220)	160.6 (4080)	187.2 (4755)	66.1 (1680)	39.6 (1005)	5	6.5	4000 (1814)	3950 (1790)	
	147 (3740)	93.7 (2380)	168.5 (4280)	195.1 (4955)	72.4 (1840)	45.9 (1165)	5	6.5	4000 (1814)	3950 (1790)	
Full Free-Lift 3-Stage (FSV)	159 (4040)	101.2 (2570)	180.3 (4580)	206.9 (5255)	79.9 (2030)	53.3 (1355)	5	6.5	4000 (1814)	3950 (1790)	
	147 (3740)	69.7 (1770)	168.3 (4275)	195.1 (4955)	48.6 (1235)	21.9 (555)	5	6.5	3950 (1791)	3750 (1700)	
	159 (4040)	73.6 (1870)	180.1 (4575)	206.9 (5255)	52.6 (1335)	25.8 (655)	5	6.5	3900 (1769)	3750 (1700)	
	170.5 (4340)	77.6 (1970)	191.9 (4875)	218.7 (5555)	56.5 (1435)	29.7 (755)	5	6.5	3950 (1740)	3680 (1670)	
	189 (4800)	83.5 (2120)	209.6 (5325)	236.4 (6005)	62.4 (1585)	35.6 (905)	5	6.5	3750 (1700)	3370 (1530)	
	198 (5040)	87.4 (2220)	219.5 (5575)	246.3 (6255)	66.3 (1685)	39.6 (1005)	5	6.5	3500 (1587)	2980 (1350)	
Open-View Full Free-Lift 3-Stage (FSW)	218 (5540)	93.7 (2380)	239.2 (6075)	265.9 (6755)	72.6 (1845)	45.9 (1165)	5	6.5	3300 (1496)	2490 (1130)	
	237.5 (6040)	101.2 (2570)	258.9 (6575)	285.6 (7255)	80.1 (2035)	53.3 (1355)	5	6.5	2550 (1156)	1790 (810)	
	189 (4800)	83.3 (2115)	207.8 (5275)	236.2 (6000)	63.3 (1605)	35 (890)	5	6.5	3480 (1315)	TSDR	
	204.5 (5200)	88.3 (2240)	222.8 (5660)	251.2 (6380)	68.3 (1735)	40 (1015)	5	6.5	3250 (1180)	TSDR	
	224.5 (5700)	95.3 (2420)	243.8 (6195)	272.5 (6920)	75.4 (1915)	47.1 (1195)	5	6.5	2850 (1030)	TSDR	
	228.5 (5800)	99.3 (2520)	246.8 (6265)	275.2 (6990)	79.3 (2015)	51 (1295)	5	6.5	2750 (995)	TSDR	
Full Free-Lift 4-Stage (QFV)	241.5 (6135)	83.5 (2120)	262.6 (6670)	289.4 (7350)	62.4 (1585)	35.6 (905)	5	3	2800 (1270)	2250 (1020)	
	259.6 (6595)	89.4 (2270)	281.3 (7145)	307.5 (7810)	68.3 (1735)	41.5 (1055)	5	3	2550 (1157)	1990 (900)	
	277.5 (7055)	95.7 (2430)	299.4 (7605)	325.6 (8270)	74.6 (1895)	47.8 (1215)	5	3	1850 (839)	1410 (640) ¹	



شرکت پارسی صنعت

فروش و خدمات پس از فروش

لیفتراک ، ریچ تراک ، پالت تراک و استاکر تویوتا

فروش 09190670300 خدمات پس از فروش 09190670200

TOYOTA

MATERIAL HANDLING